

Z1166/...

Mat.: 2.0060
DIN 46228-1

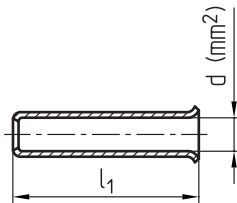

▶ Info



max. °C	l ₁	d	mm ²	Nr./No.
120	6	1	0,1 -0,5	Z1166/0,1 -0,5
		1,4	0,75	0,75
	7	1,8	1,5	1,5
		2,3	2,5	2,5

Z1167/...

CE

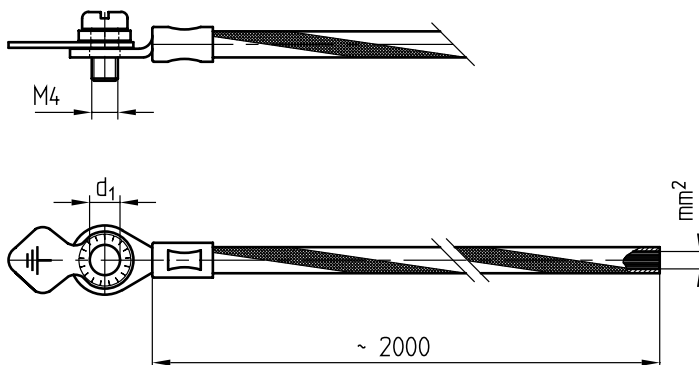

d ₁	mm ²	Nr./No.
4,3	1,5	Z1167/1,5
	4	4

This is trial version
www.adultpdf.com